

Stud type track rollers KRE...-PP

with axial guidance, with eccentric collar, plastic axial plain washers on both sides

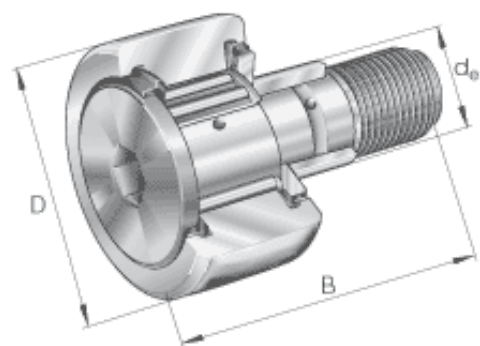

	D	d_e	B			
	mm	mm	mm			
KRE16-PP	16	9	28			
KRE19-PP	19	11	32			
KRE22-PP	22	13	36			
KRE26-PP	26	13	36			
KRE30-PP	30	15	40			
KRE32-PP	32	15	40			
KRE35-PP	35	20	52			
KRE40-PP	40	22	58			
KRE47-PP	47	24	66			
KRE52-PP	52	24	66			
KRE62-PP	62	28	80			
KRE72-PP	72	28	80			
KRE80-PP	80	35	100			
KRE90-PP	90	35	100			

D **d_e** **B**
mm mm mm