

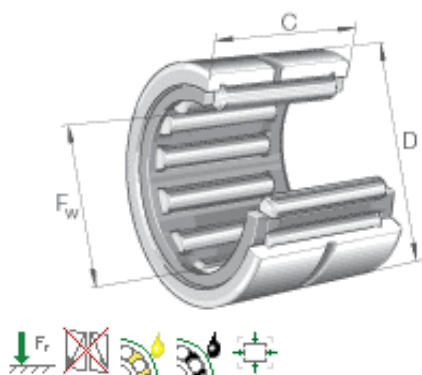













































































































# Needle roller bearings NK

light series







































































	$F_w$	D	C			
	mm	mm	mm			
NK5/10-TV	5	10	10			
NK5/12-TV	5	10	12			
NK6/10-TV	6	12	10			
NK6/12-TV	6	12	12			
NK7/10-TV	7	14	10			
NK7/12-TV	7	14	12			
NK8/12-TV	8	15	12			
NK8/16-TV	8	15	16			
NK9/12-TV	9	16	12			
NK9/16-TV	9	16	16			
NK10/12-TV	10	17	12			
NK10/16-TV	10	17	16			
NK12/12	12	19	12			
NK12/16	12	19	16			
NK14/16	14	22	16			
NK14/20	14	22	20			
NK15/16	15	23	16			
NK15/20	15	23	20			
NK16/16	16	24	16			
NK16/20	16	24	20			
	$F_w$	D	C			
	mm	mm	mm			
NK17/16	17	25	16			
NK17/20	17	25	20			
NK18/16	18	26	16			
NK18/20	18	26	20			
NK19/16	19	27	16			
NK19/20	19	27	20			
NK20/16	20	28	16			
NK20/20	20	28	20			
NK21/16	21	29	16			
NK21/20	21	29	20			
NK22/16	22	30	16			
NK22/20	22	30	20			
NK24/16	24	32	16			

## Needle roller bearings - NK

<b>NK24/20</b>	24	32	20			
<b>NK25/16</b>	25	33	16			
<b>NK25/20</b>	25	33	20			
<b>NK26/16</b>	26	34	16			
<b>NK26/20</b>	26	34	20			
<b>NK28/20</b>	28	37	20			
<b>NK28/30</b>	28	37	30			
	<b>F<sub>w</sub></b>	<b>D</b>	<b>C</b>			
	mm	mm	mm			
<b>NK29/20-TV</b>	29	38	20			
<b>NK29/30</b>	29	38	30			
<b>NK30/20-TV</b>	30	40	20			
<b>NK30/30-TV</b>	30	40	30			
<b>NK32/20-TV</b>	32	42	20			
<b>NK32/30</b>	32	42	30			
<b>NK35/20-TV</b>	35	45	20			
<b>NK35/30-TV</b>	35	45	30			
<b>NK37/20</b>	37	47	20			
<b>NK37/30</b>	37	47	30			
<b>NK38/20</b>	38	48	20			
<b>NK38/30</b>	38	48	30			
<b>NK40/20-TV</b>	40	50	20			
<b>NK40/30</b>	40	50	30			
<b>NK42/20</b>	42	52	20			
<b>NK42/30</b>	42	52	30			
<b>NK43/20</b>	43	53	20			
<b>NK43/30</b>	43	53	30			
<b>NK45/20-TV</b>	45	55	20			
<b>NK45/30-TV</b>	45	55	30			
	<b>F<sub>w</sub></b>	<b>D</b>	<b>C</b>			
	mm	mm	mm			
<b>NK47/20</b>	47	57	20			
<b>NK47/30</b>	47	57	30			
<b>NK50/25-TV</b>	50	62	25			
<b>NK50/35-TV</b>	50	62	35			
<b>NK55/25</b>	55	68	25			
<b>NK55/35</b>	55	68	35			
<b>NK60/25-TV</b>	60	72	25			
<b>NK60/35</b>	60	72	35			
<b>NK65/25</b>	65	78	25			

## Needle roller bearings - NK

<b>NK65/35</b>	65	78	35			
<b>NK68/25</b>	68	82	25			
<b>NK68/35</b>	68	82	35			
<b>NK70/25</b>	70	85	25			
<b>NK70/35</b>	70	85	35			
<b>NK73/25</b>	73	90	25			
<b>NK73/35</b>	73	90	35			
<b>NK75/25</b>	75	92	25			
<b>NK75/35</b>	75	92	35			
<b>NK80/25</b>	80	95	25			
<b>NK80/35</b>	80	95	35			
	<b>F<sub>w</sub></b>	<b>D</b>	<b>C</b>			
	mm	mm	mm			
<b>NK85/25</b>	85	105	25			
<b>NK85/35</b>	85	105	35			
<b>NK90/25</b>	90	110	25			
<b>NK90/35</b>	90	110	35			
<b>NK95/26</b>	95	115	26			
<b>NK95/36</b>	95	115	36			
<b>NK100/26</b>	100	120	26			
<b>NK100/36</b>	100	120	36			
<b>NK105/26</b>	105	125	26			
<b>NK105/36</b>	105	125	36			
<b>NK110/30</b>	110	130	30			
<b>NK110/40</b>	110	130	40			
	<b>F<sub>w</sub></b>	<b>D</b>	<b>C</b>			
	mm	mm	mm			